

# Introduction to Bioengineering

## BIOE/ENGR.80

### Stanford University

Spring 2020 Class Slides

Day 18  
15 May 2020

These slides are made freely available to the fullest extent possible. Any copyrighted images used herein are used in good faith subject to the fair use exception for education. Please contact [endy@stanford.edu](mailto:endy@stanford.edu) directly re: any copyright concerns.

# Week 6 look ahead

CONCEPT  
SKILL

Diffusion of molecules (space, time, abundances)

Programming patterns in autonomous systems

Programming patterns in living systems

WE ARE HERE

## [Team Project]

- Brainstorms (three themes)
- Team Rules

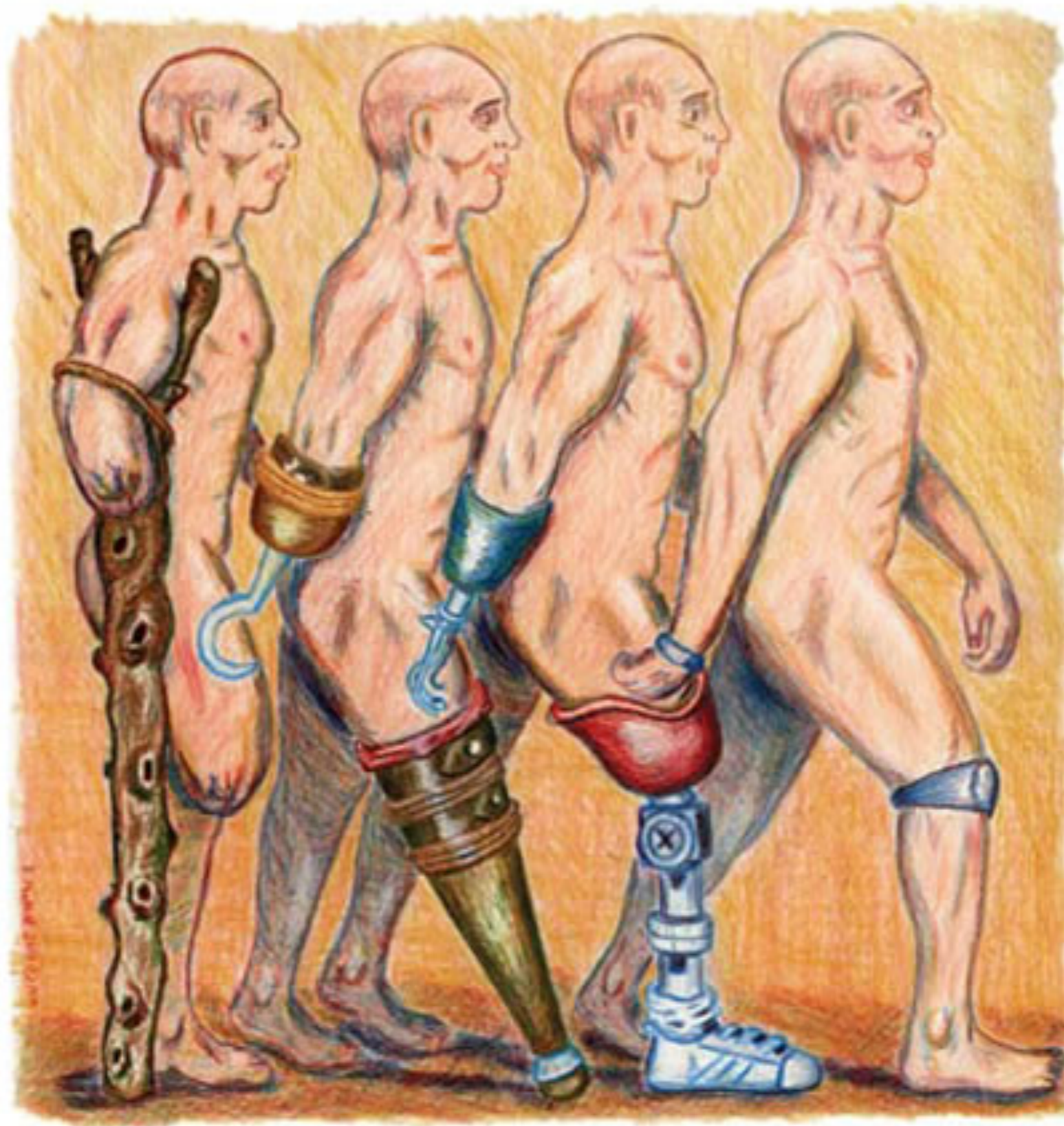



# Doing the “impossible”

How to decide what impossible things are actually possible?

How to organize people and resources to make the impossible true? I.e., how to plan and deliver?

Lessons learned?

How do you get started?

Ups and downs?

What happens after success?

Other?





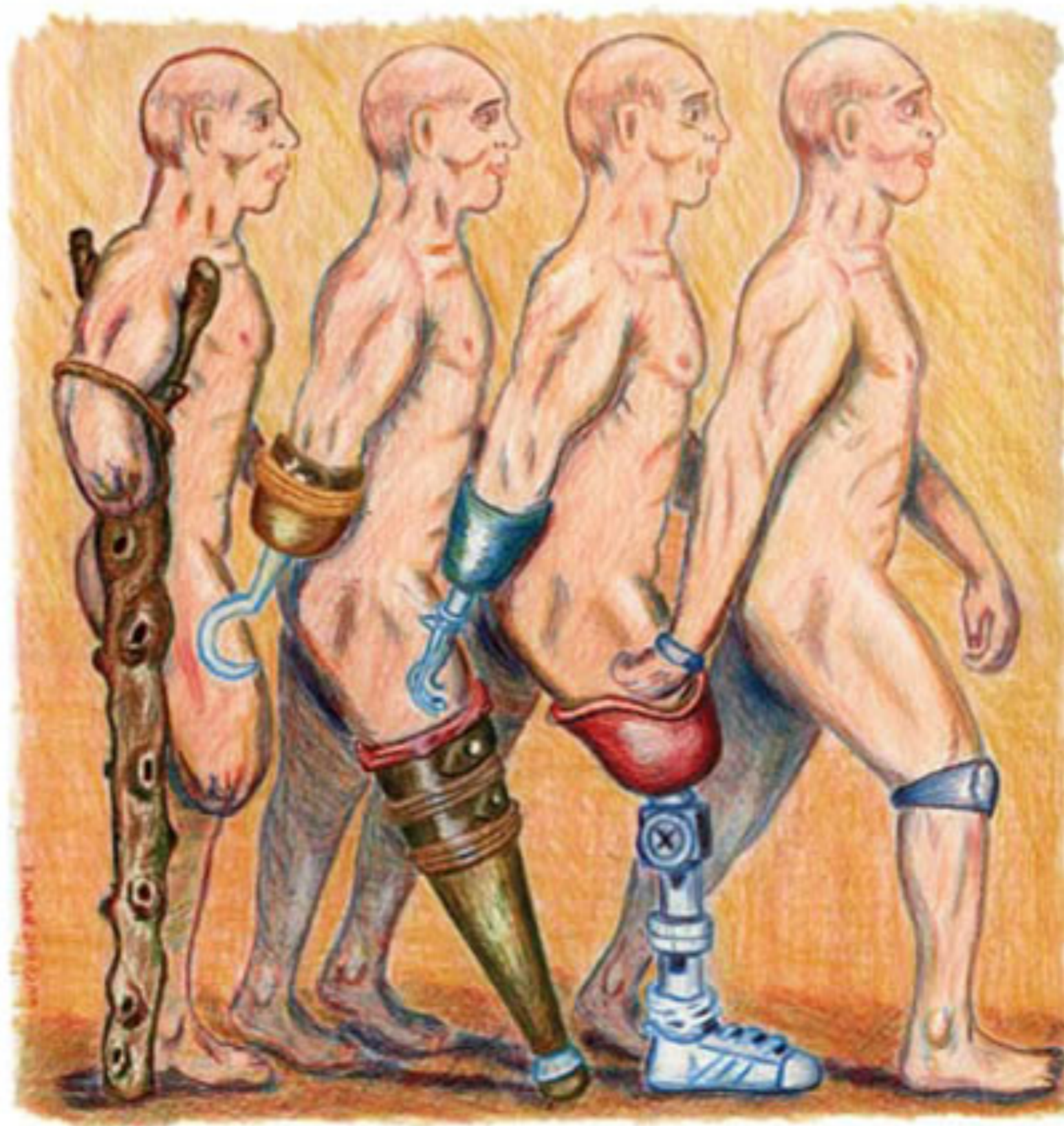





# Concentrated source

(stuff, energy, other)

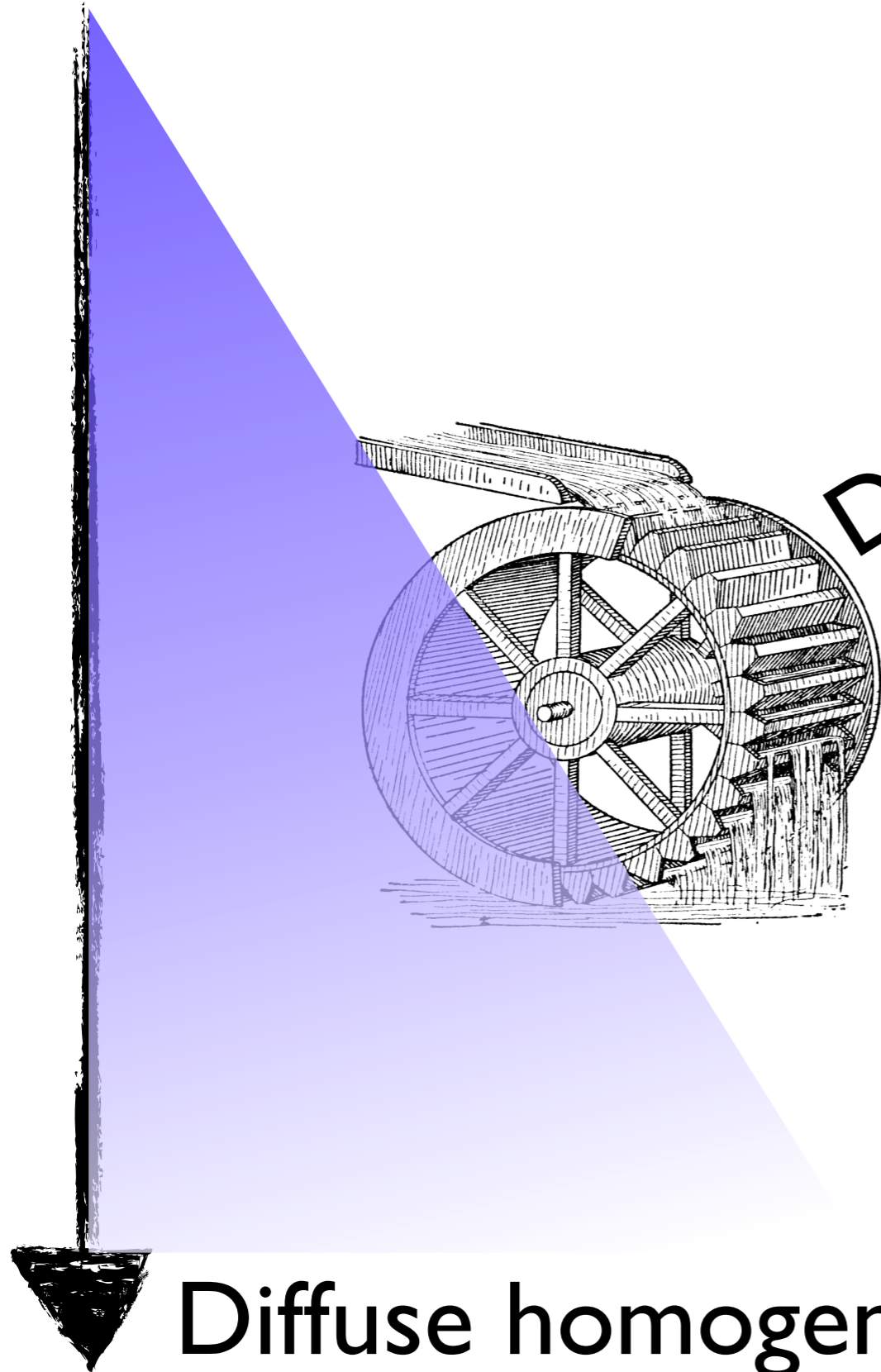

Do something!

**For cells, doing something can mean...**

1. Grow & divide
2. Move
3. Communicate
4. Change state
5. Self destruct
6. Other

Diffuse homogeneity  
(heat death, etc)

# What's the simplest way you could grow a limb-like shape?

## Challenge I — 'hand of god'

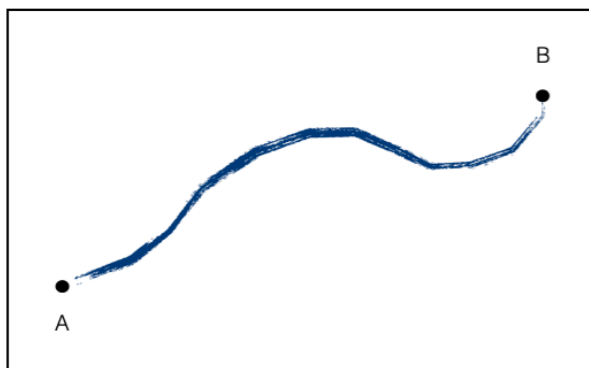

Draw a physical pattern on the slide that gets droplets to move from point A to point B (i.e., you are explicitly directing the behavior from outside the system)

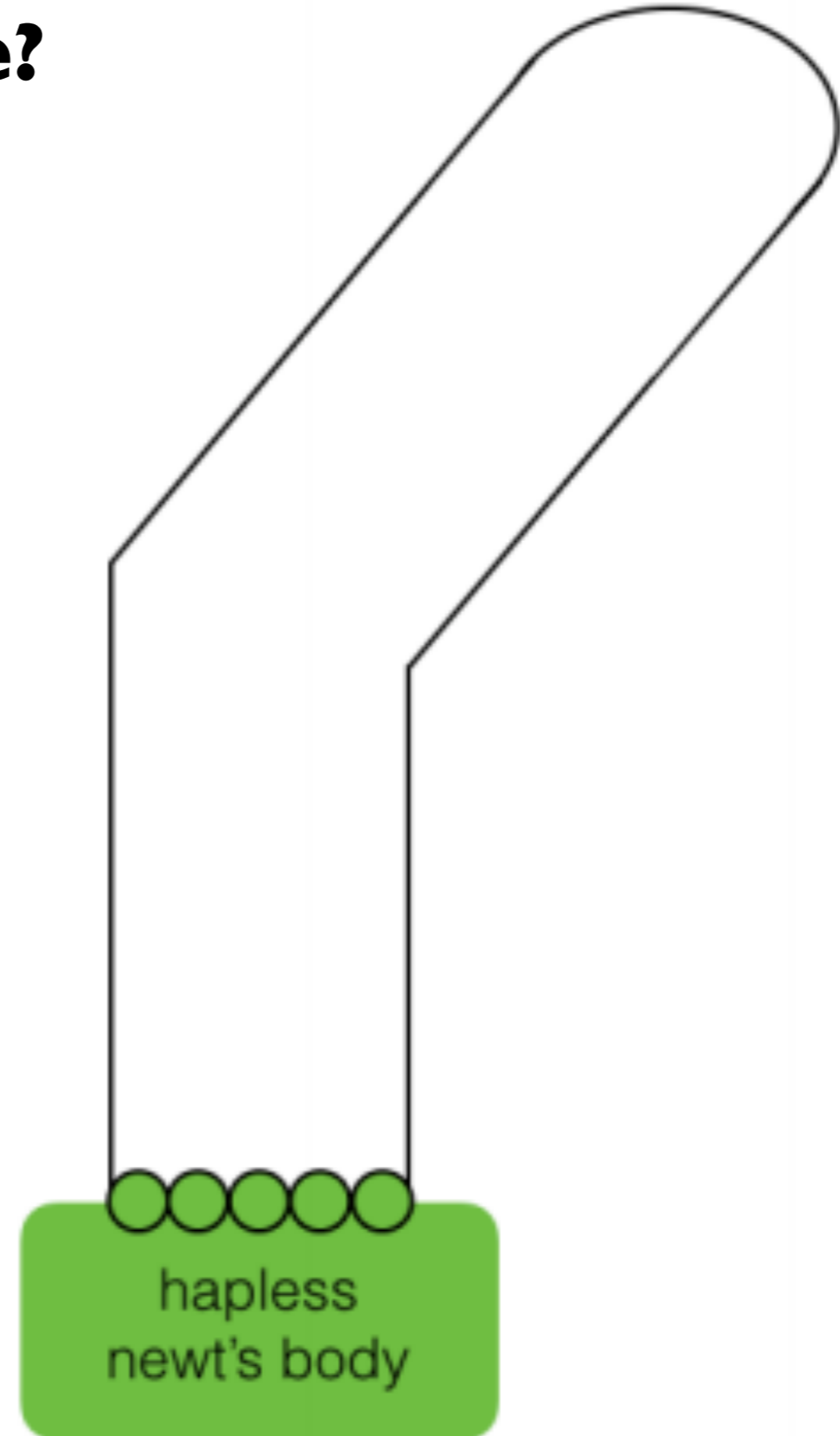



# What if there was no guiding hand, but there were external points of reference?

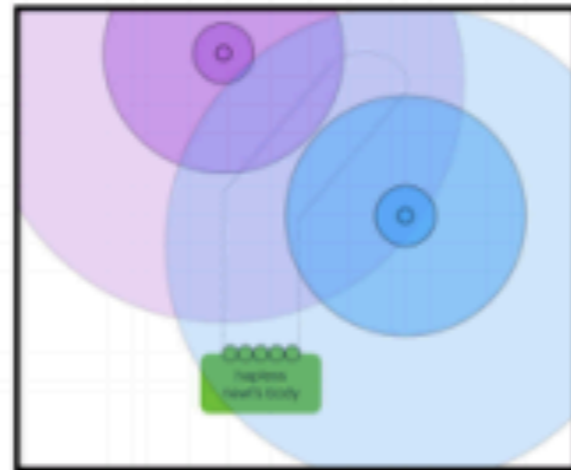

time > 0

## Challenge 2 — 'external coordinates'

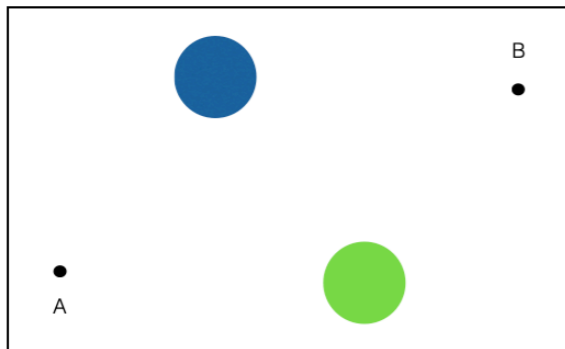

Place droplets on the slide that establish a coordinate system, causing another droplet to move from point A to point B (i.e., you make a coordinate system but droplets otherwise on their own).

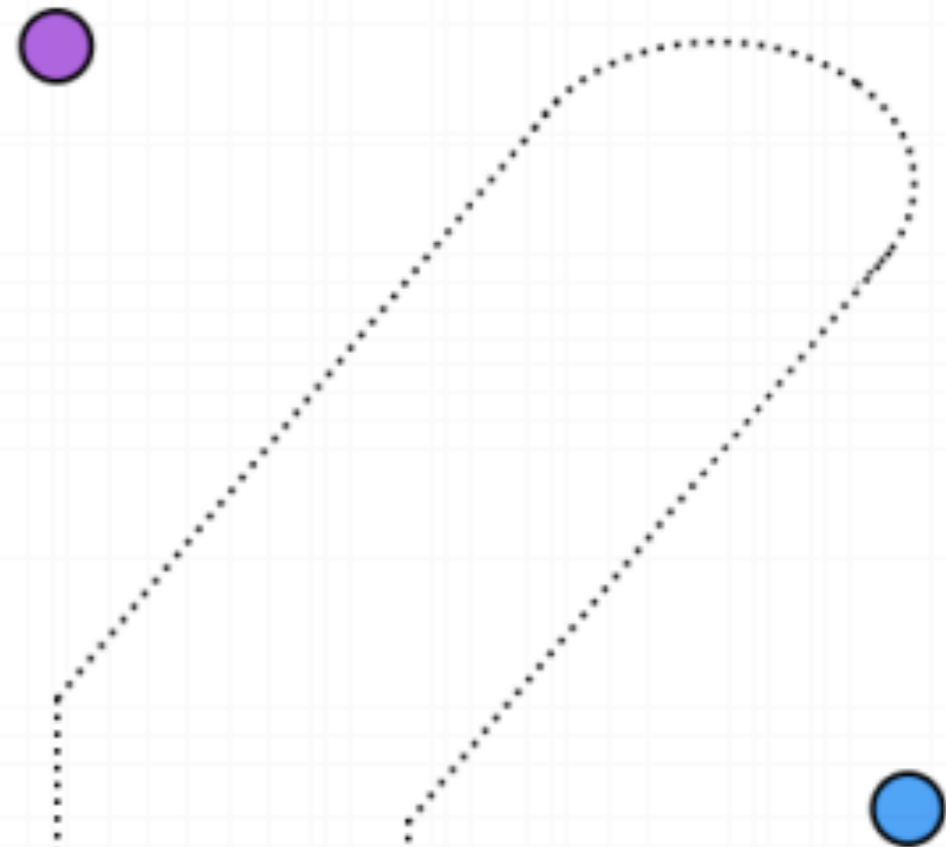

hapless  
newt's body

time = 0

# What if there were no external points of reference?

## Challenge 3 — 'autonomous coordination'

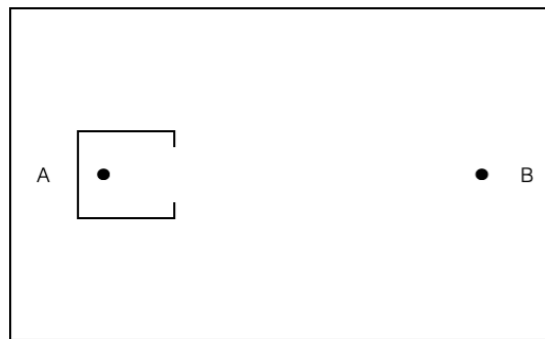

Place droplets only in the seed box that causes a droplet to move from point A to point B (i.e., seed a system that autonomously controls its own behavior).

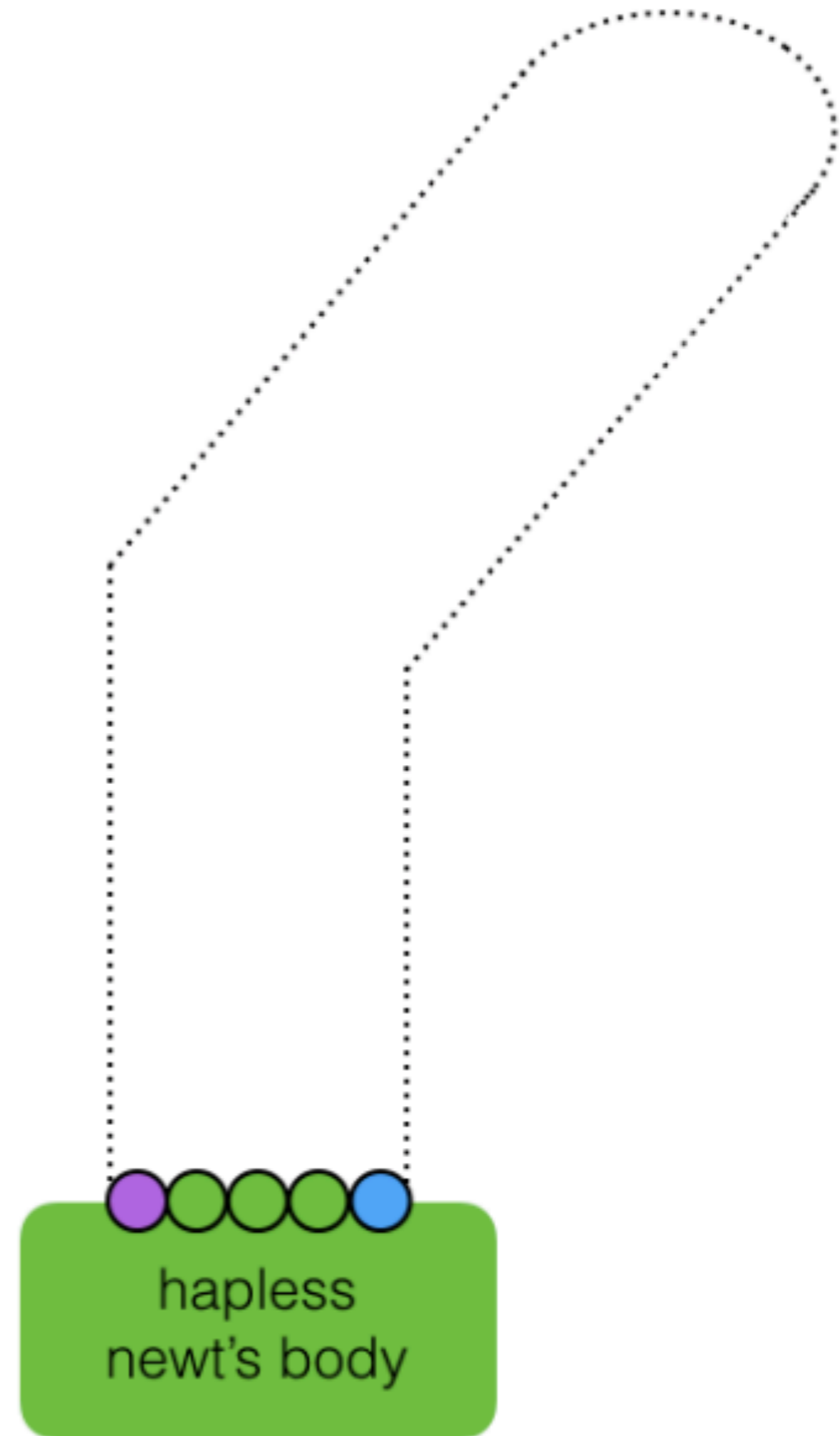

OK. So, how would you grow a yin yang from a single seed cell?

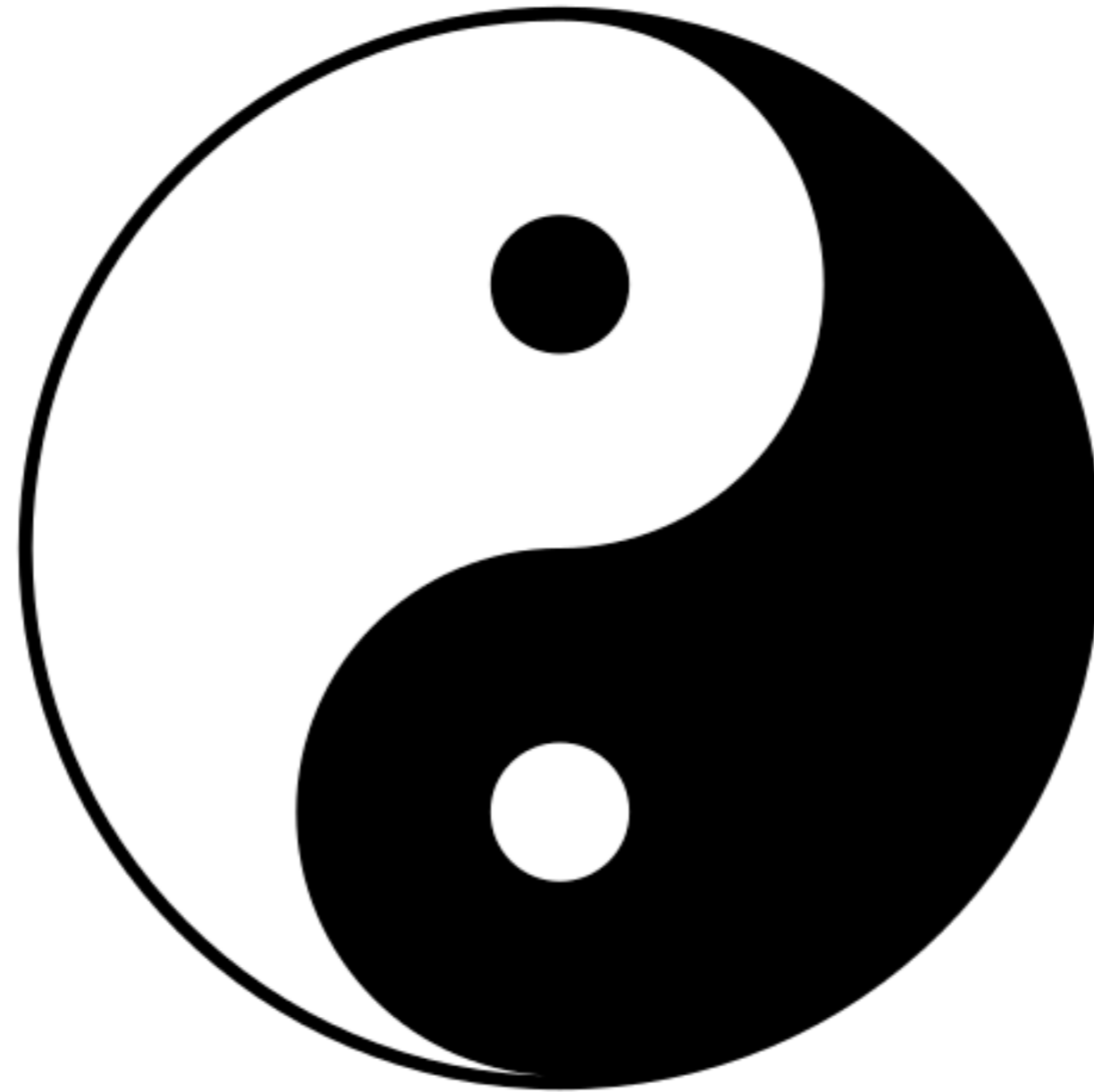



Take a complicated problem and break it down into a set of simpler problems...

A

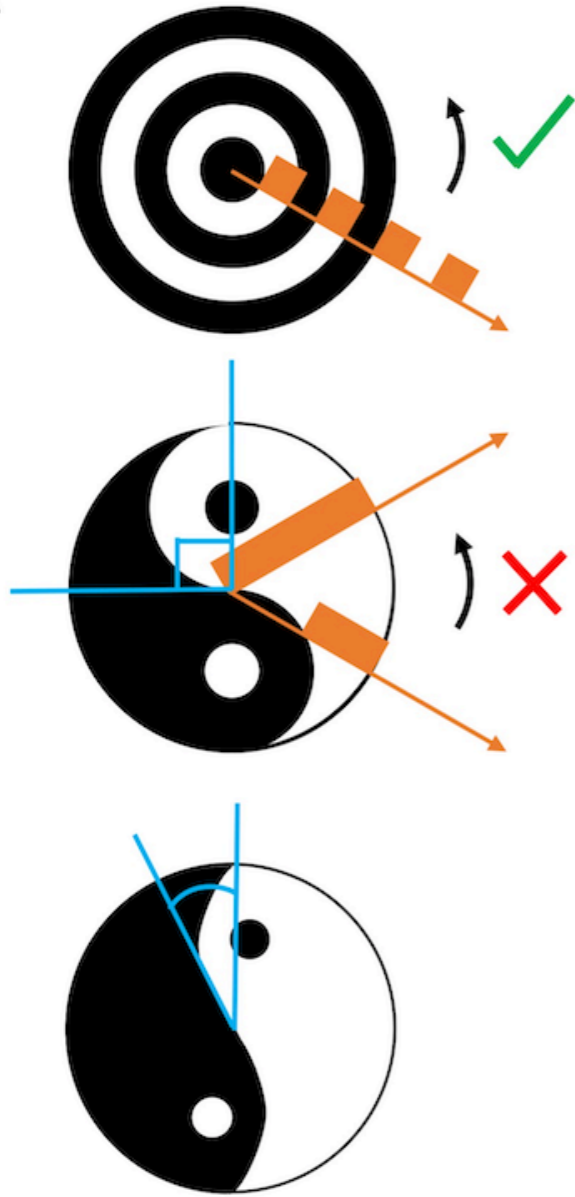

B

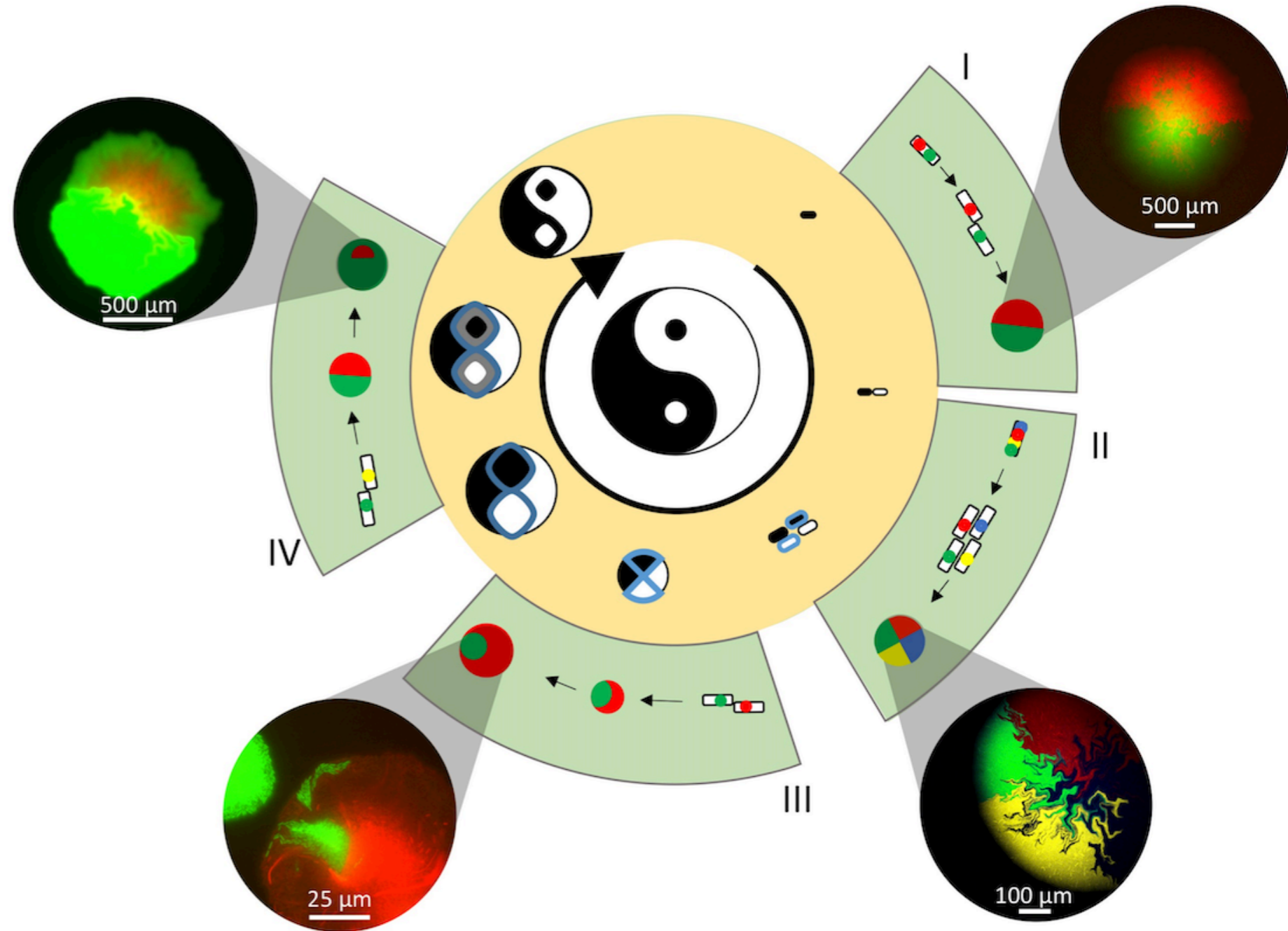

One interesting aspect is how the mechanical, chemical, and biological realms are coupled... how can we leverage such couplings as bioengineers?

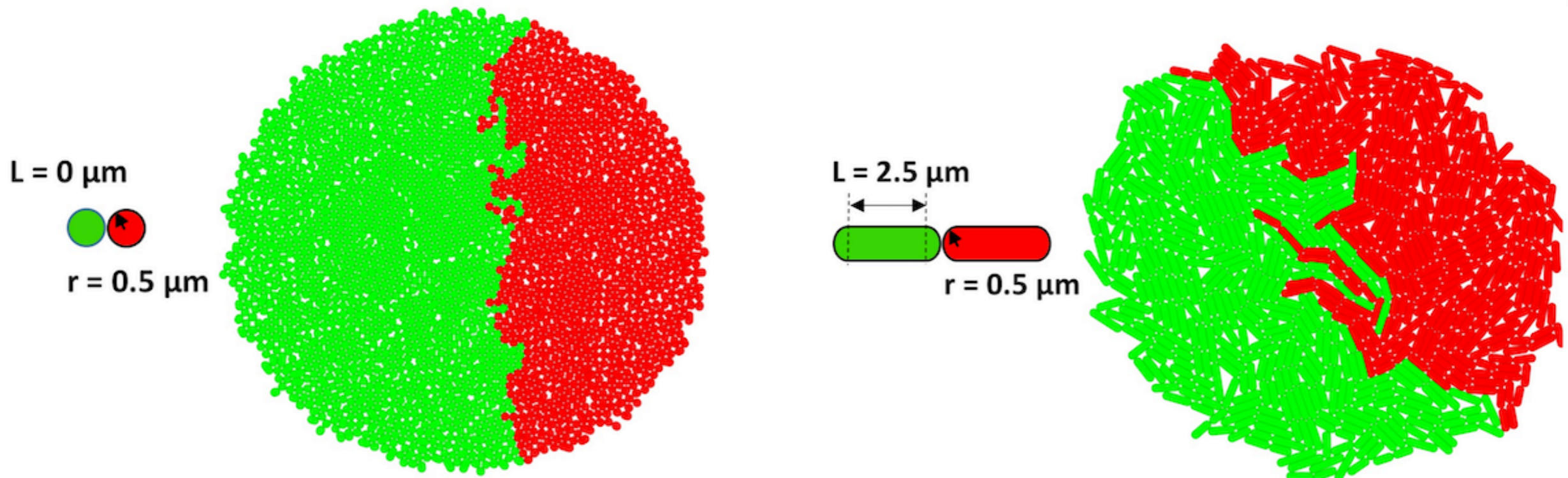

Just changing two simple variables (relative growth rates and cell lengths) can produce all of the below...

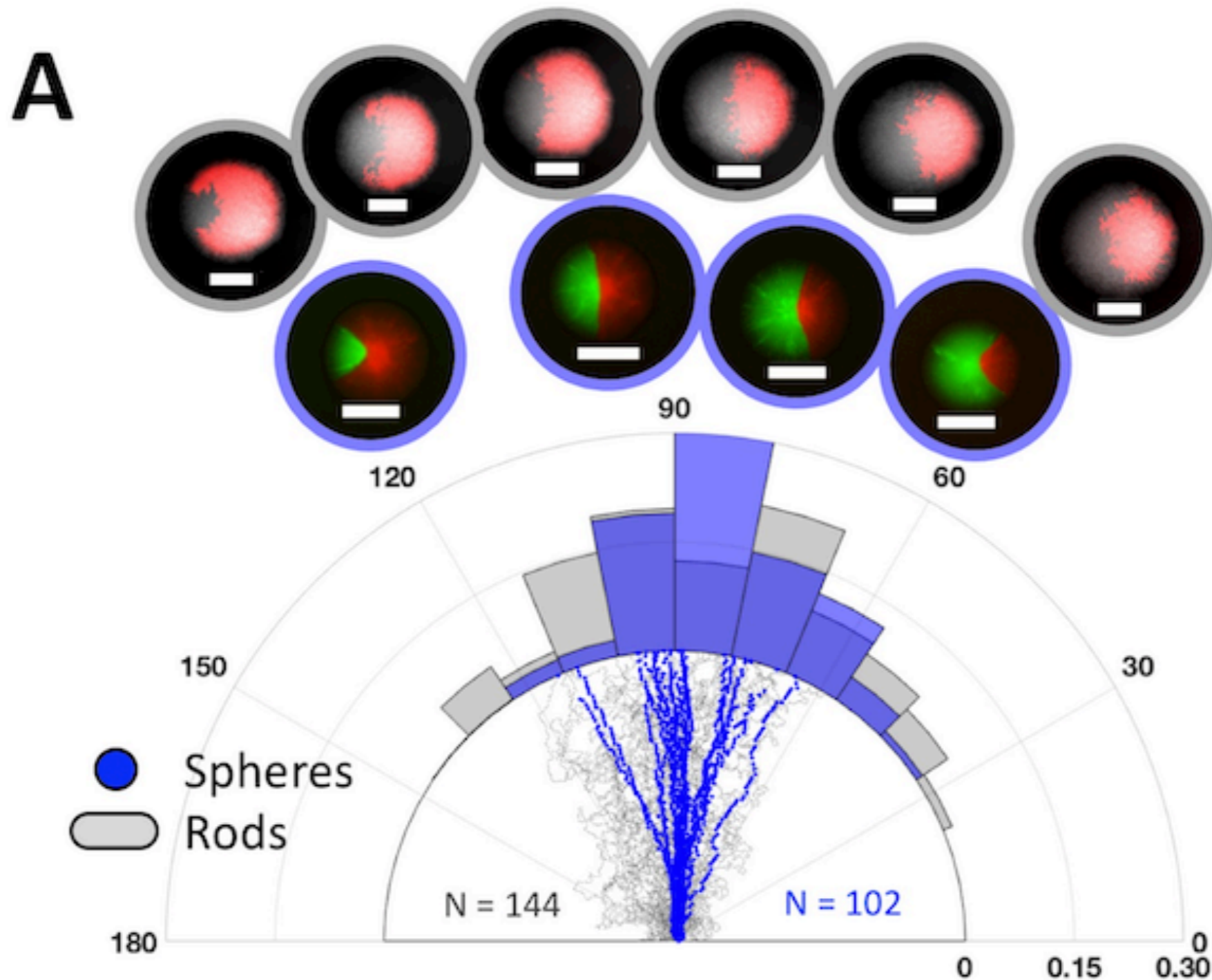



# Abstraction again appears as a tool for managing biocompleixty...

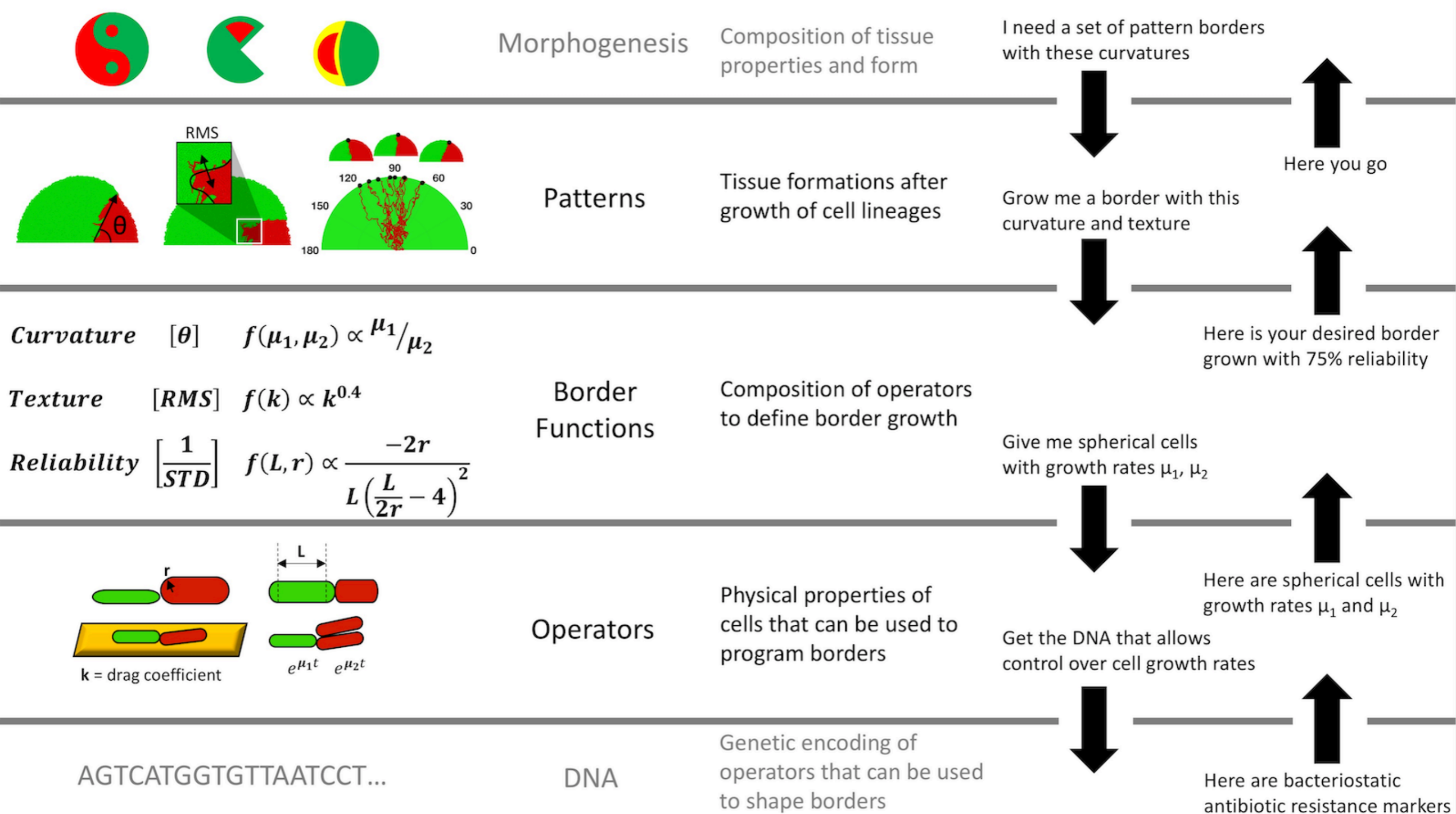

AGTCATGGTGTTAATCCT...

DNA

So, can bioengineers grow arbitrary patterns from living cells, from scratch?

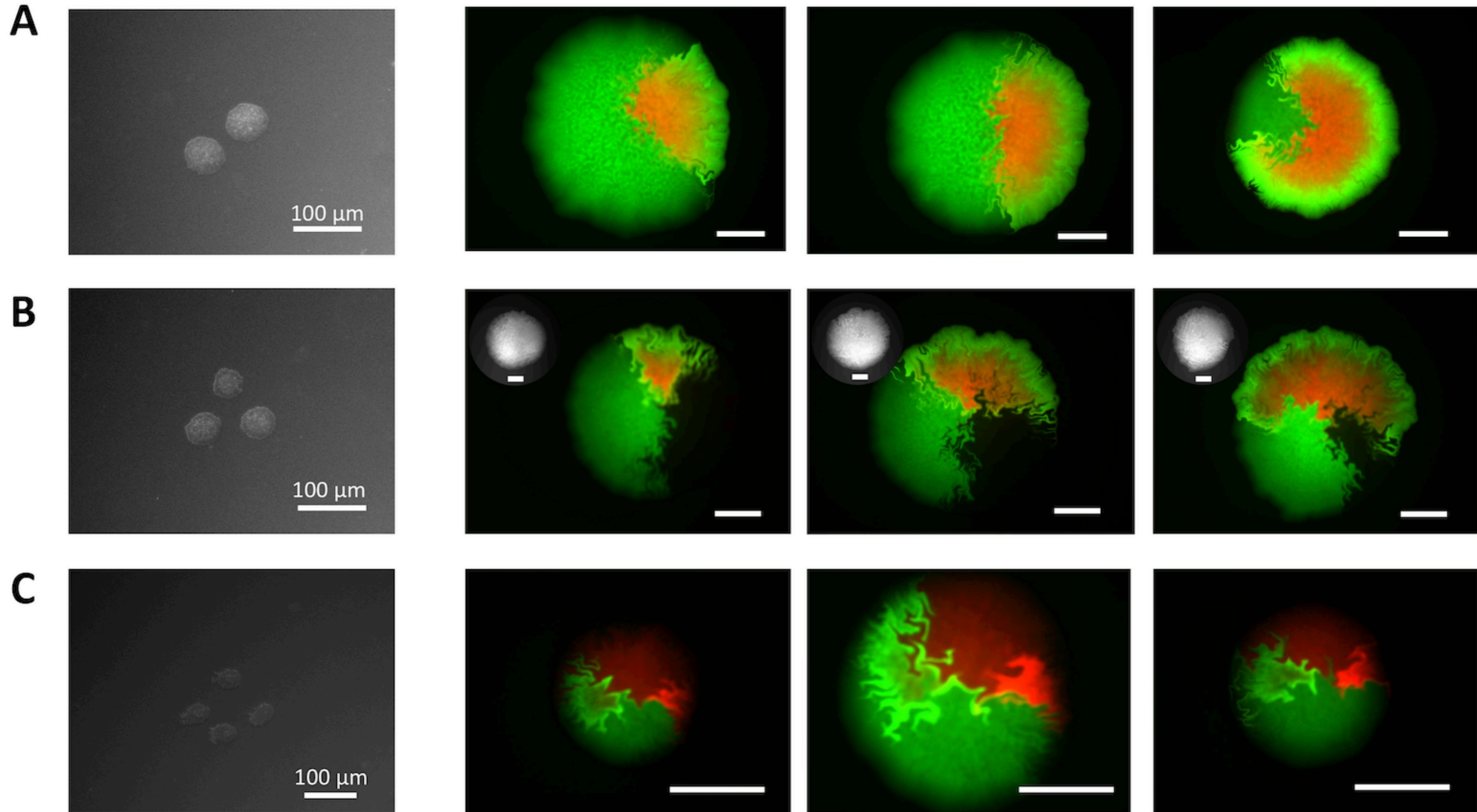



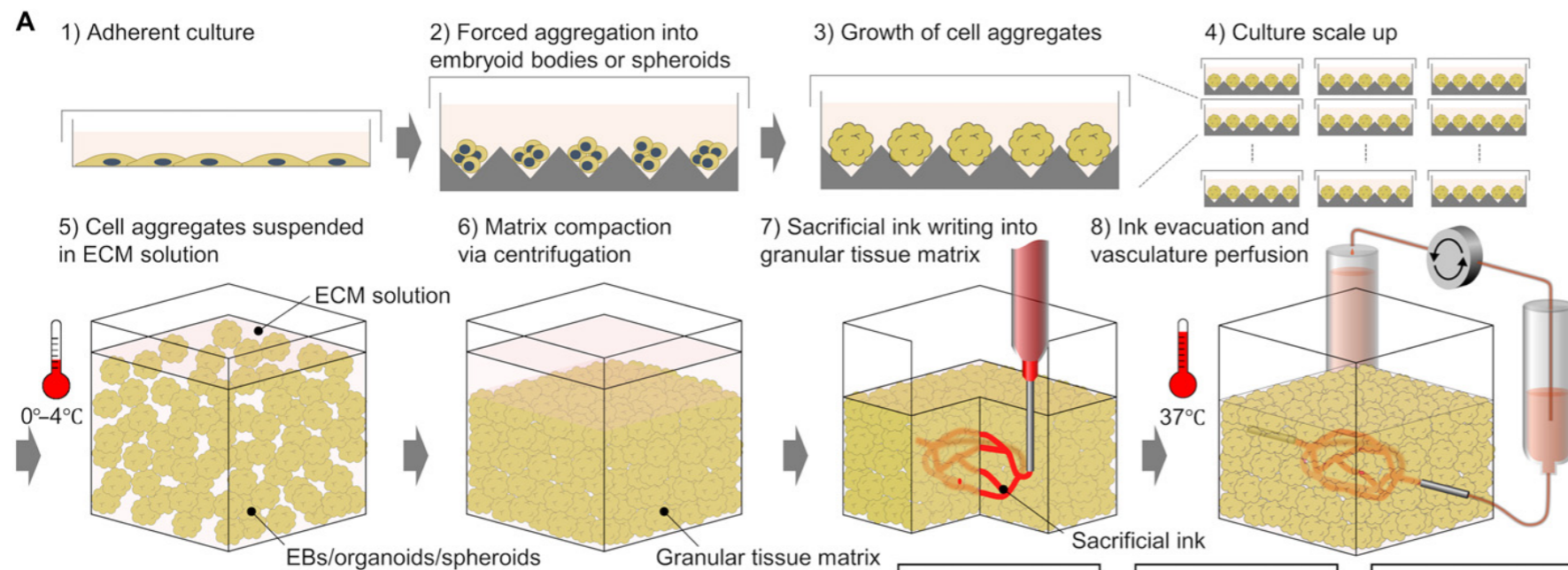

What about a hybrid approach?

Use the biology for what the biology is good at, combined with what we can control from outside!

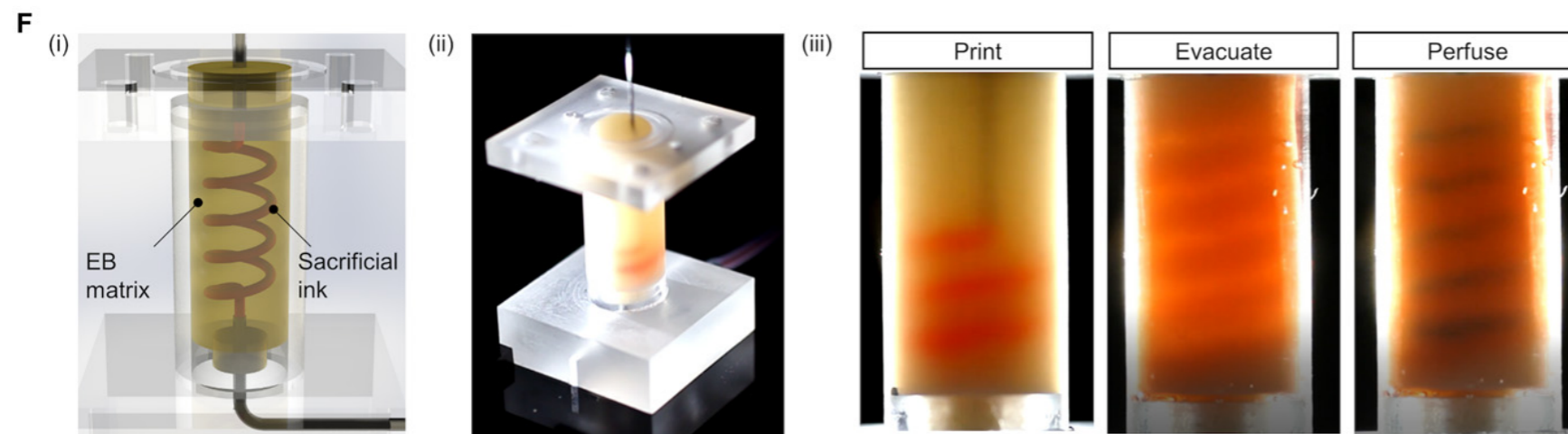
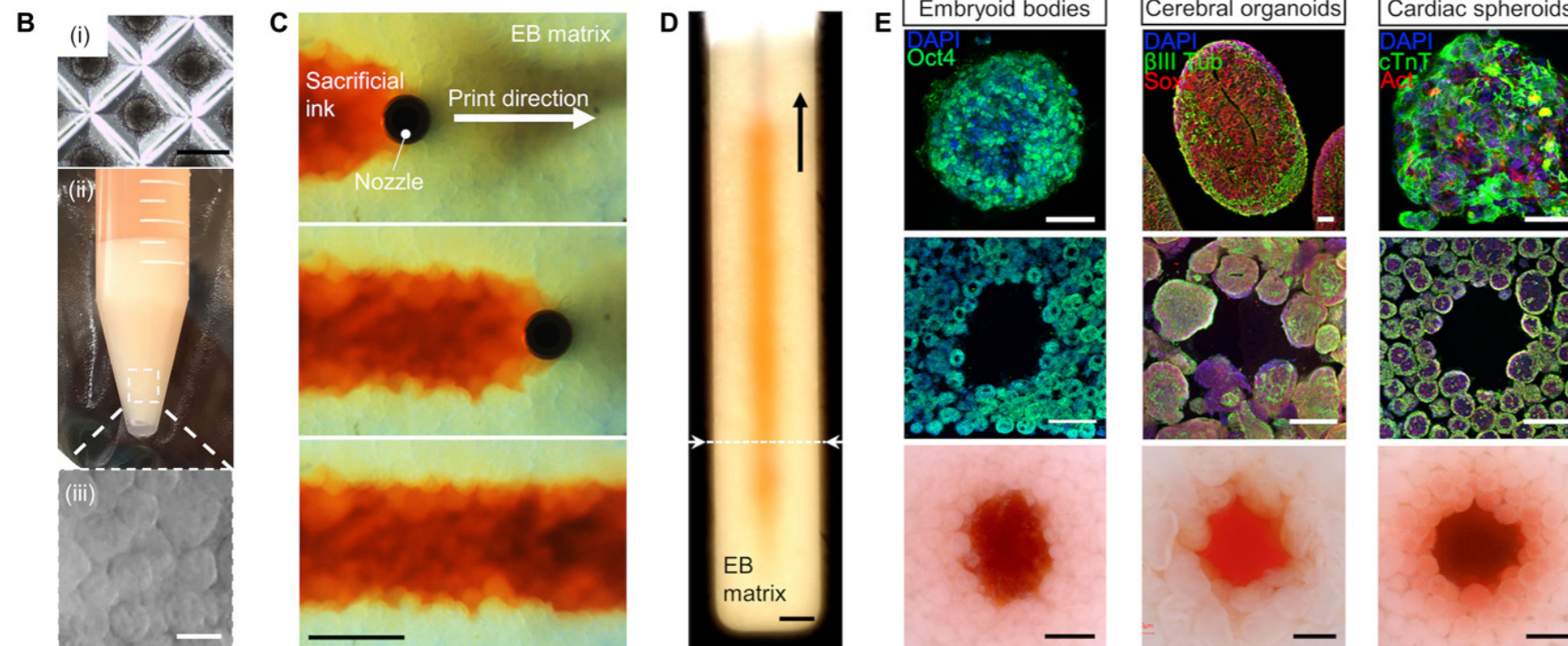

Vascular system on demand?



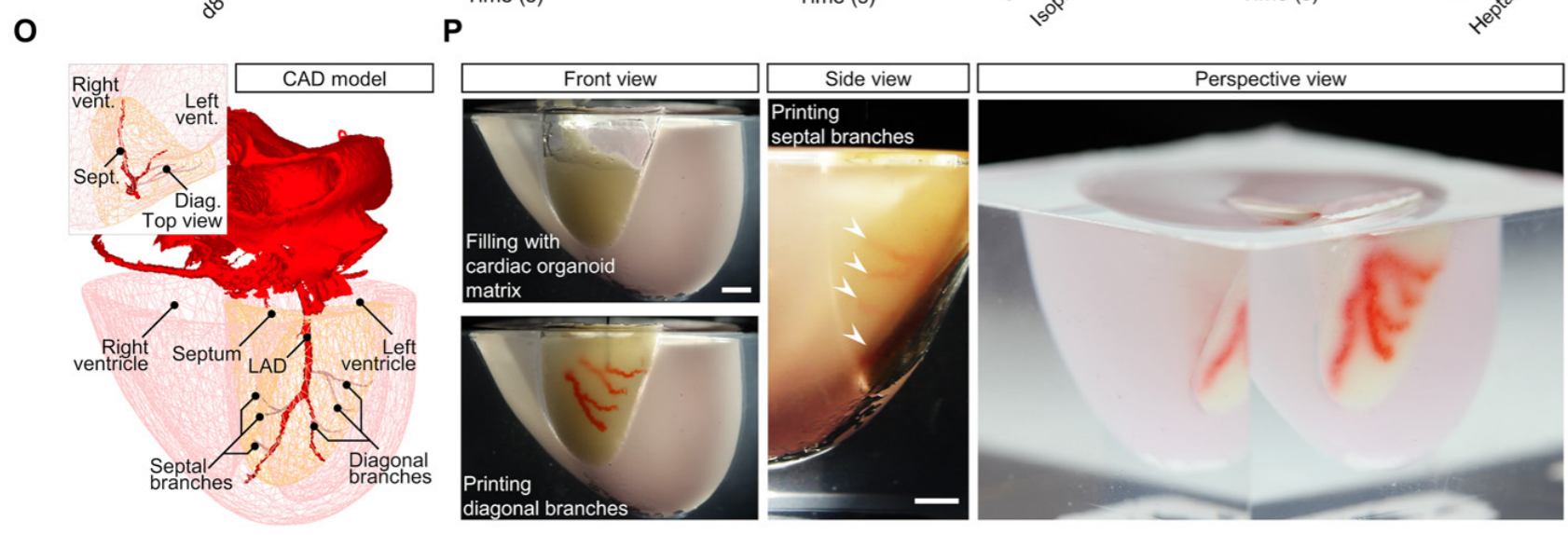
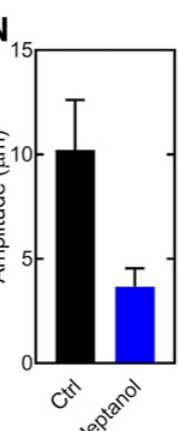
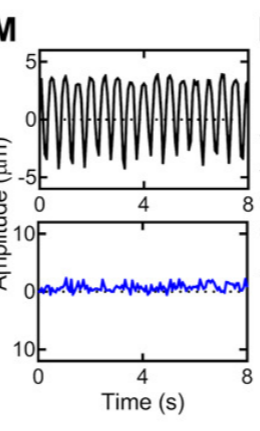
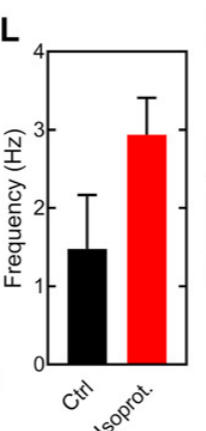
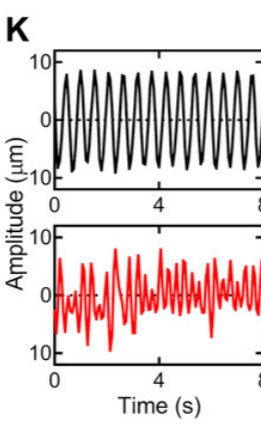
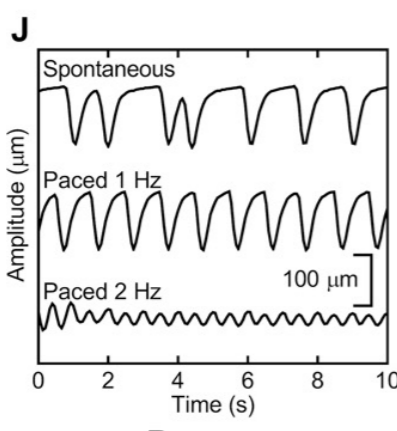
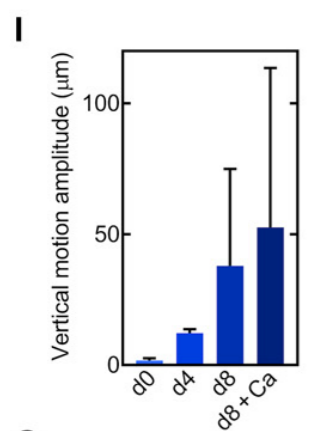
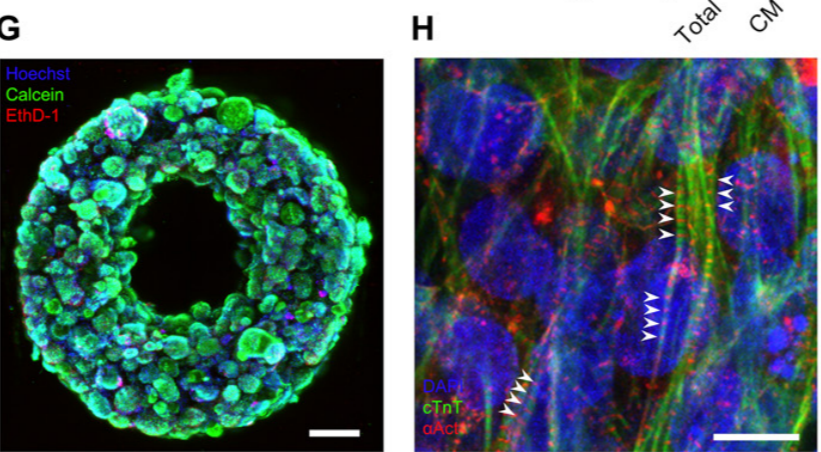
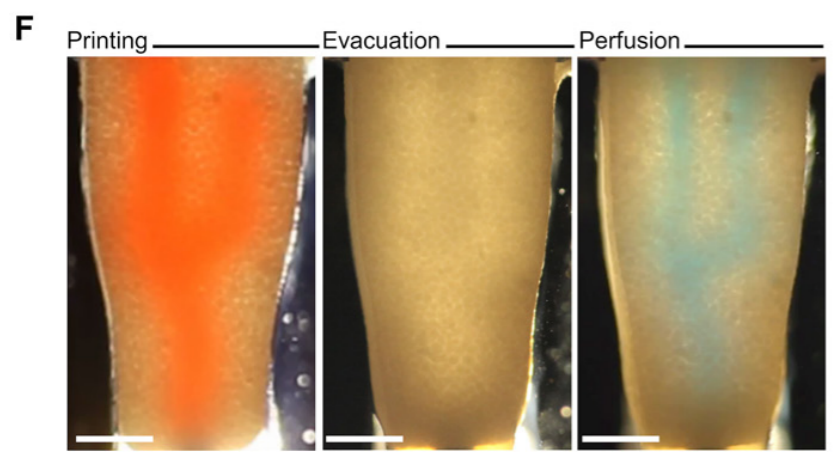
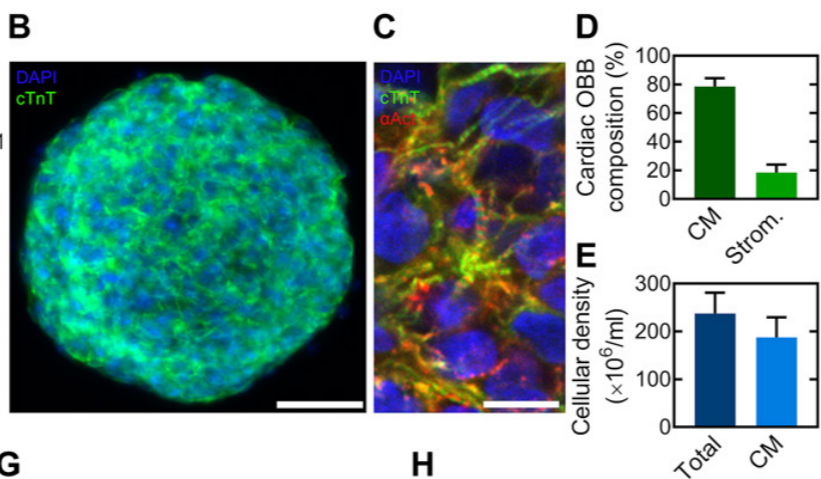
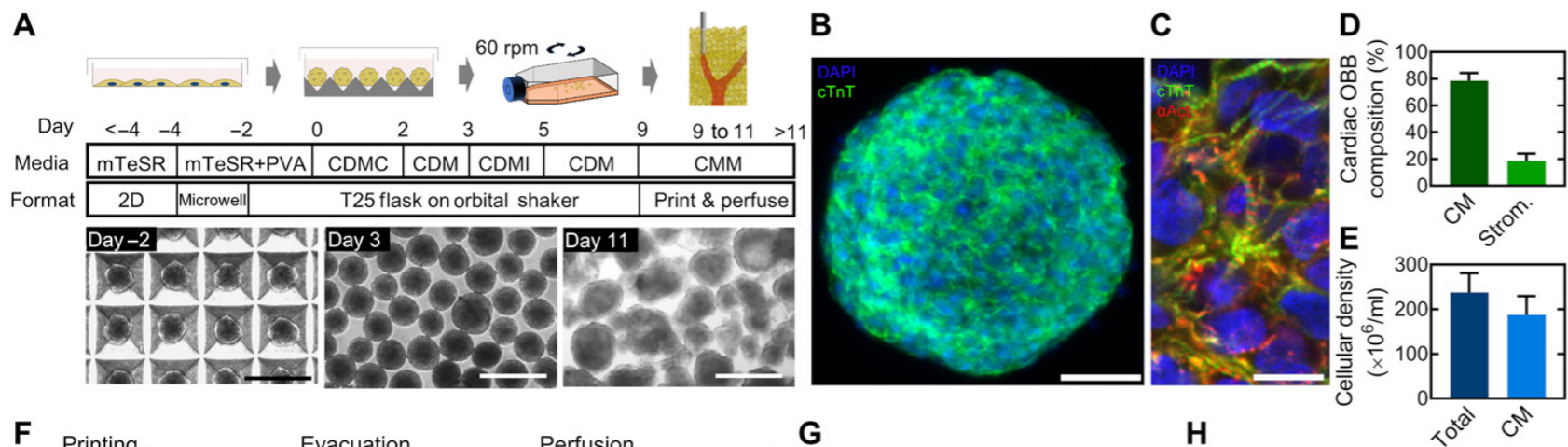

What about a hybrid approach?

Use the biology for what the biology is good at, combined with what we can control from outside!

Cardiac vascular system on demand?



# Same hybrid approach... Living 3D printed bionic coral

